

Objímka RI

Výhody



- Vysoká pevnosť vďaka dvojitému vystuženiu rebier
- Silná vložka z EPDM: (zvukovo) izolovaná
- Skrutky sa nedajú stratiť
- Pevný zvar matice
- Matica so závitom M8 a M10 pre rôzne aplikácie
- Teplotná odolnosť: -50 °C až +110 °C, vhodné pre teplovodné a vykurovacie potrubia



Certifikáty a schválenia



Montáž

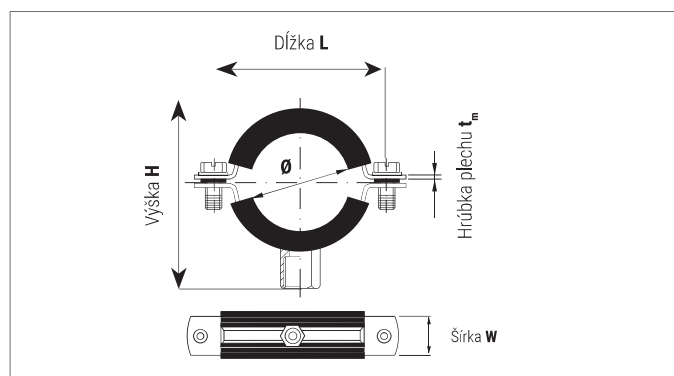

Objímka RI



RI s pripojovacím závitom M8 + M10

Typ	Objednávací kód	pre rúry-Ø			Vnútorný Ø [mm]	Nosnosť* ≤ [kg]	Hrúbka plechu t _m [mm]	Dĺžka L [mm]	Výška H [mm]	Šírka objímky W [mm]	€/100 ks	[ks]
		Med' [mm]	Oceľ [palce]	Plast [mm]								
RI 18	918RI	18	3/8"	–	15-19	80	1,5	60,0	40,5	20		100
RI 22	922RI	22	1/2"	–	20-24	80	1,5	62,0	45,0	20		100
RI 28	928RI	28	3/4"	25	23-28	80	1,5	70,5	49,5	20		100
RI 35	935RI	35	1"	32	31-36	80	1,5	79,0	60,0	20		100
RI 40	940RI	42	1-1/4"	40	38-44	100	1,5	88,0	64,0	20		100
RI 48	948RI	–	1-1/2"	50	44-50	100	1,5	94,0	70,5	20		100
RI 54	954RI	54	–	–	54-58	100	1,5	102,0	81,5	20		50
RI 60	960RI	–	2"	–	59-65	100	1,5	109,0	86,5	20		50
RI 75	975RI	76	2-1/2"	75	74-80	150	2,0	133,0	102,5	25		50
RI 90	990RI	89	3"	90	83-93	150	2,0	145,0	111,5	25		50
RI 100	9100RI	–	3-1/2"	100	95-103	150	2,0	155,0	116,0	25		50
RI 110	9110RI	108	4"	110	108-118	150	2,0	169,0	122,0	25		50
RI 125	9125RI	–	4-1/2"	125	121-127	150	2,0	128,8	135,5	25		50
RI 140	9140RI	–	5"	140	133-143	150	2,0	198,5	145,5	25		50
RI 160	9160RI	–	6"	160	159-169	150	2,0	229,0	161,5	25		40
RI 200	9200RI	–	–	200	198-202	150	2,0	262,0	184,5	25		40
RI 250	9250RI	–	–	250	249-254	200	2,0	290,0	275,0	25		30
RI 355 ¹⁾	9355RI	–	–	355	354-359	200	2,3	396,0	381,0	20		20

* Zaťaženie vrátane bezpečnostného faktora

¹⁾ Ukončená výroba, len do vypredania zásob



Sady RI objímok



Typ	Objednávací kód	Ø-hmoždinky [mm]	Dĺžka hmoždinky [mm]	Nosnosť* ≤ [kg]	Obsah sady	€/blister	[ks]	[blister]
FX 10 RI 22	22RIEDRN	10	50	80	FX 10 + M8x80 + RI 22		2	15
FX 10 RI 28	28RIEDRN	10	50	80	FX 10 + M8x80 + RI 28		2	15
FX 10 RI 35	35RIEDRN	10	50	80	FX 10 + M8x80 + RI 35		2	15
FX 10 RI 40	40RIEDRN	10	50	100	FX 10 + M8x80 + RI 40		2	15
FX 10 RI 50	50RIEDRN	10	50	100	FX 10 + M8x80 + RI 50		2	15
FX 10 RI 60	60RIEDRN	10	50	100	FX 10 + M8x80 + RI 60		2	15
FX 10 RI 75	75RIEDRN	10	50	150	FX 10 + M8x80 + RI 75		2	15
FX 12 RI 90	90RIEDRN	12	60	150	FX 12 + M10x100 + RI 90		2	15
FX 12 RI 110	110RIEDRN	12	60	150	FX 12 + M10x100 + RI 110		2	15

* Zaťaženie vrátane bezpečnostného faktora