

CELO

Made in Germany



Distance mounting system ResiTHERM®

The approved heavy-duty fixing
for insulated façades

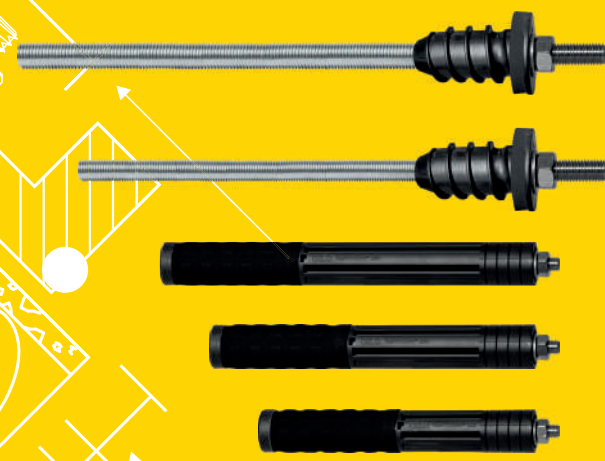

ResiTHERM®

Makes the difference!
Fastening heavy loads to insulated facades
- approved, fast and rain-tight



Innovative

ResiTHERM® 16 & 12 are the only distance mounting systems in the market **impervious to driving rain**.

ResiTHERM® 16 is winner of the special mention GERMAN DESIGN AWARD 2023 due to its innovative design!

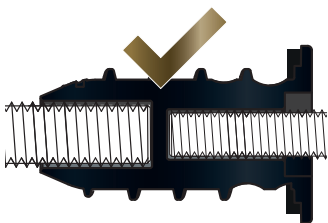

Smart

The ResiTHERM® distance mounting system is built to guarantee **energy efficiency and cost reduction, no thermal bridges**.

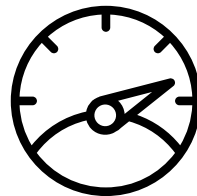

Efficient

The **fastest distance mounting system in the market** – fewer mounting steps, fastest mounting process. See details on page 9



Approved

The first distance mounting system to obtain a **European Technical Assessment/Approval (ETA)**, a widely accepted confirmation of technical suitability of a building product in member states of the EU and beyond.

What is a distance mounting system?

Heavy-duty fastening on insulated façades

Distance mounting system ResiTHERM® 16

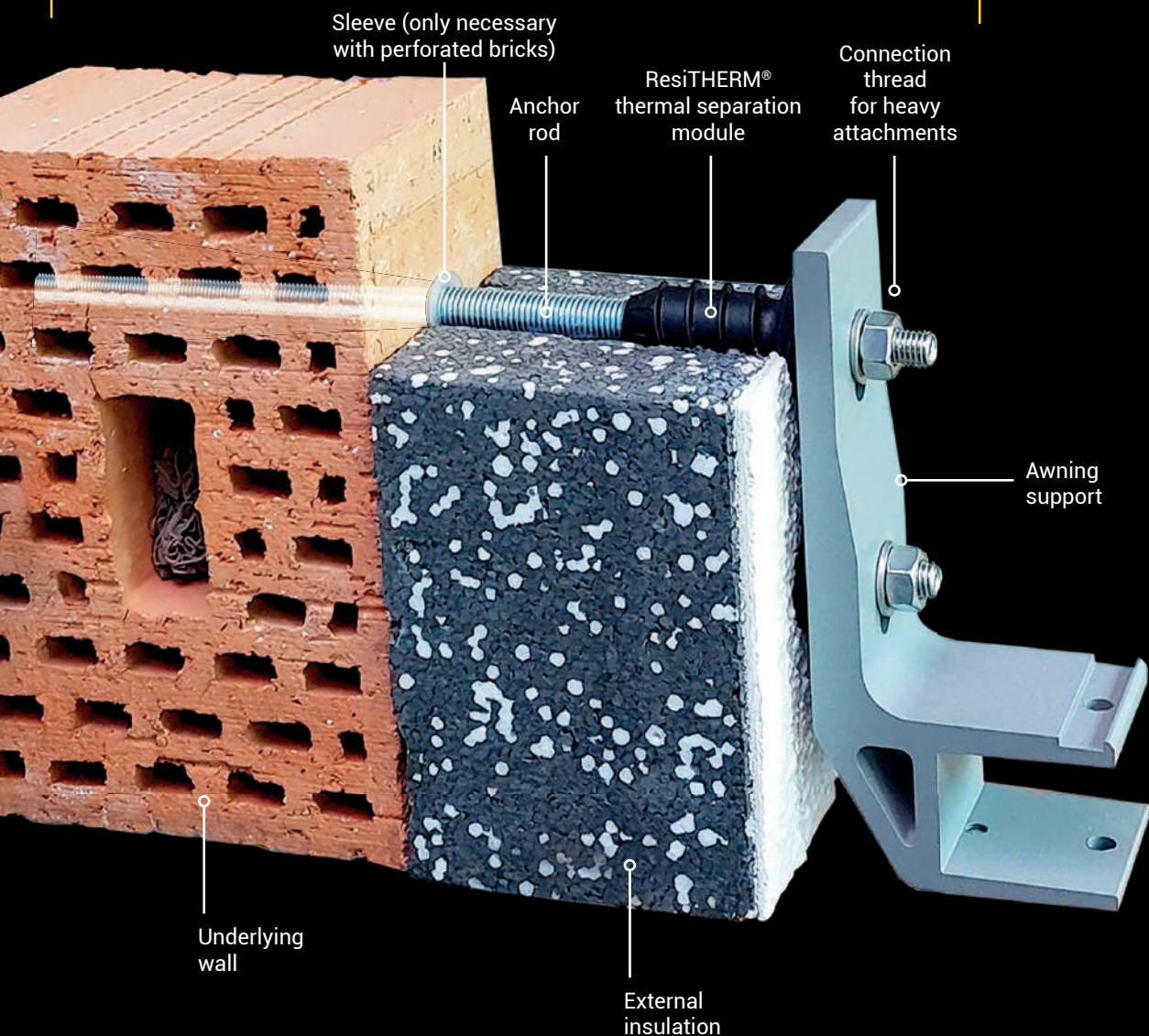

What is distance mounting?

The assembly of heavy loads such as French balconies, canopies, satellite systems or air conditioning units on an ETICS (External Thermal Insulation Composite System) insulated façade is a challenge, because the insulation alone does not provide enough support for heavy load installation.

Distance mounting, spacer mounting or stand-off installation now means that the fastening solution bridges a distance that does not offer enough support for installation (in this case the thermal insulation) - by means of an anchor rod. It anchors itself securely in the underlying wall, offering reliable support for the fixing on the exterior of the façade.

Where to use a distance mounting system?

CELO's **ResiTHERM**® range of distance mounting system has been developed especially for fixing heavy loads to insulated facades (ETICS).

The approved products can be used for a wide range of applications and guarantee a long-lasting, secure fixing without thermal bridges:



Fixings for awnings



Fixings for canopies



Fixings for French balconies



Fixings for air-conditioners



Fixings for chimneys



Fixings for satellite dishes



Fixings for sun sails



Fixings for railings



Fixings for garden hose holders

How to choose your ResiTHERM®?

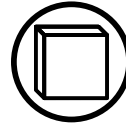
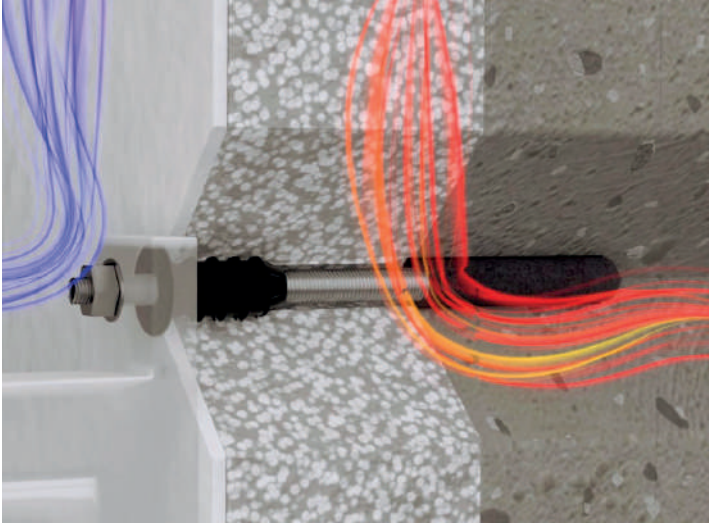

For insulated façades made of concrete, aerated concrete and solid brick



ResiTHERM® 16 & 12

- ✓ Self-sealing
- ✓ Driving rain-tight up to wind force 11 Beaufort (hurricane-force winds) in accordance with DIN EN 1027
- ✓ ETA-approved for concrete, aerated concrete and solid brick

More from page 6

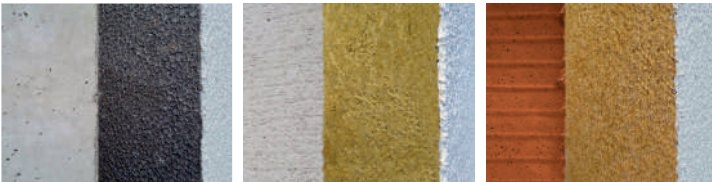

Example: Concrete, styrofoam, plaster

Example: Aerated concrete, mineral wool, plaster

Example: Solid brick, wood fibreboard, plaster

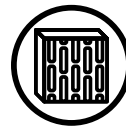
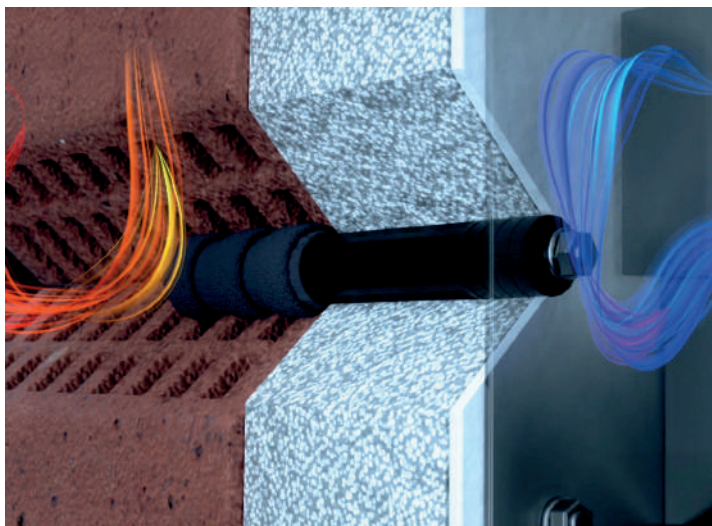

For insulated façades made of hollow brick



ResiTHERM® 37

- ✓ For highest load values in hollow brick
- ✓ ETA-approved for hollow brick and aerated concrete

More from page 18



Example: Hollow brick, styrofoam, plaster

Example: Perforated brick, mineral wool, plaster

Example: Brick with chambers, styrodur, plaster

ResiTHERM® 16 & 12

First ETA-approved distance mounting system for fixing heavy loads to insulated façades – fast, safe, easy



Reliable, durable fastening **with ETA** (European Technical Assessment / Approval)

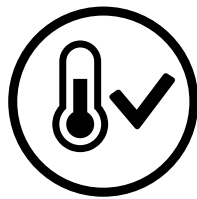

Effective thermal separation prevents cold bridges



Impervious to driving rain up to wind force 11 Beaufort (violent storm) in accordance to DIN EN 1027

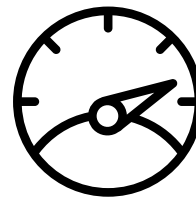

Significant time and cost savings due to simple and quick installation



High-quality materials such as A4 stainless steel and glass-fibre reinforced UV-resistant nylon



Components and advantages

ResiTHERM® 16 & 12

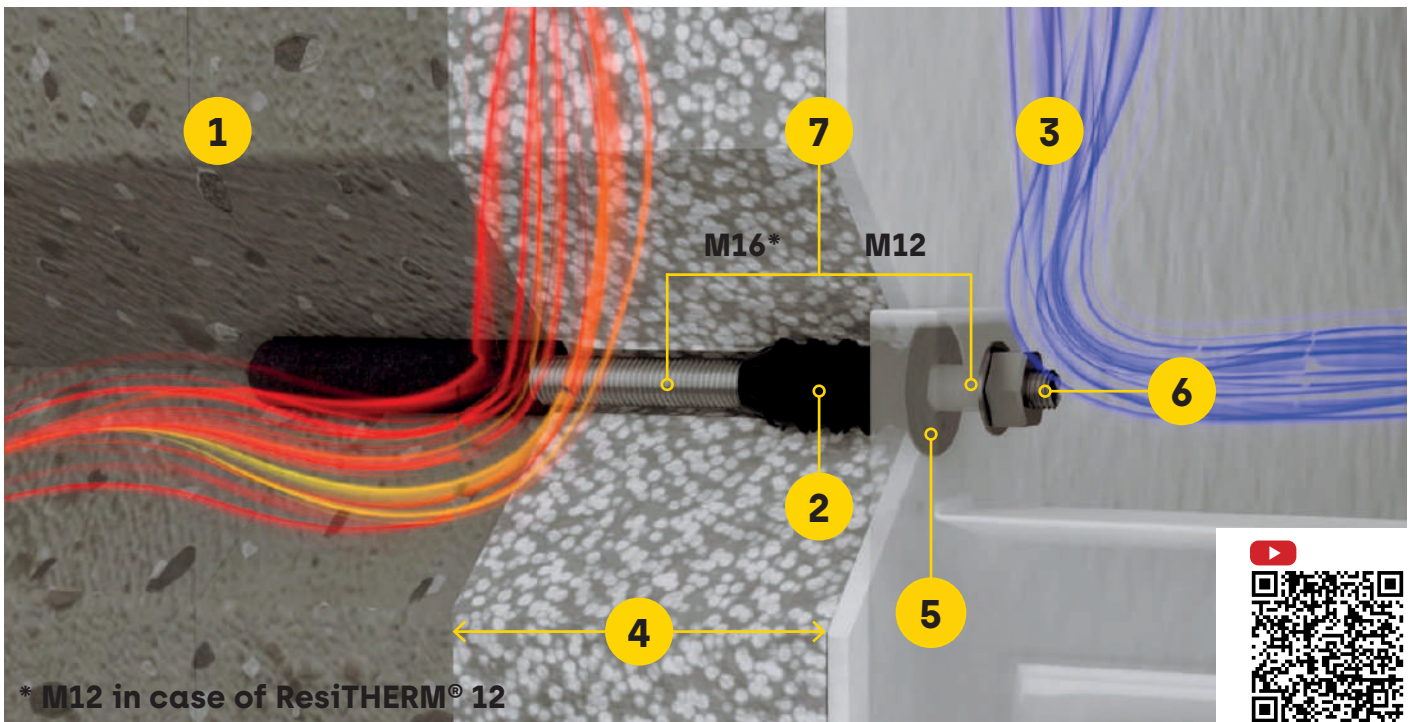

1 Suitable for all common building materials

such as concrete, aerated concrete, masonry (solid and perforated brick)

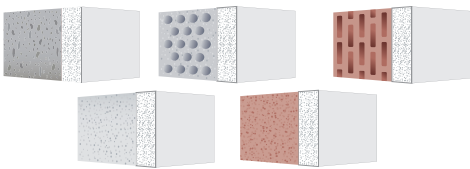

2 The unique thermal separation module

prevents thermal bridges and speeds up the installation, as the plastic thread screws itself directly into the insulation. This saves you valuable installation time.

3 No thermal bridges

Effective thermal separation prevents heat bridges and protects against mould and heat loss.

4 For all insulation types and thicknesses

ResiTHERM® 16 bridges insulation thicknesses of 60-300 mm on concrete of 60-250 mm on perforated bricks

ResiTHERM® 12 bridges insulation thicknesses of 60-220 mm on concrete of 60-160 mm on perforated bricks

5 Rain and windproof fastening

Pre-assembled and weather resistant EPDM sealing ensures clean sealing against driving rain up to wind force 11 (violent storm), watertightness based on DIN EN 1027

6 High-quality materials

Glass-fibre reinforced nylon for the thermal separation module and stainless steel A4 for the attachment parts guarantee a long-lasting anchorage

7 Available in 2 sizes

For ResiTHERM® 16, the anchor rod lying in the wall has a diameter of 16 mm (M16) whereas for ResiTHERM® 12 the diameter of the internal metric rod is 12 mm (M12).



ResiTHERM® 16 & 12 are watertight

ResiTHERM® 16 & 12 have undergone extensive testing at the „Prüfzentrum für Bauelemente“ (PfB) in Rosenheim (Germany) to ensure watertightness.

There, ResiTHERM® was installed in a rain chamber with pressure increasing stepwise, following DIN EN 1027 (method 1A). The highest pressure level corresponds to wind force 11 (Beaufort scale) or a hurricane-like storm. The test is passed if no moisture enters the insulation material.

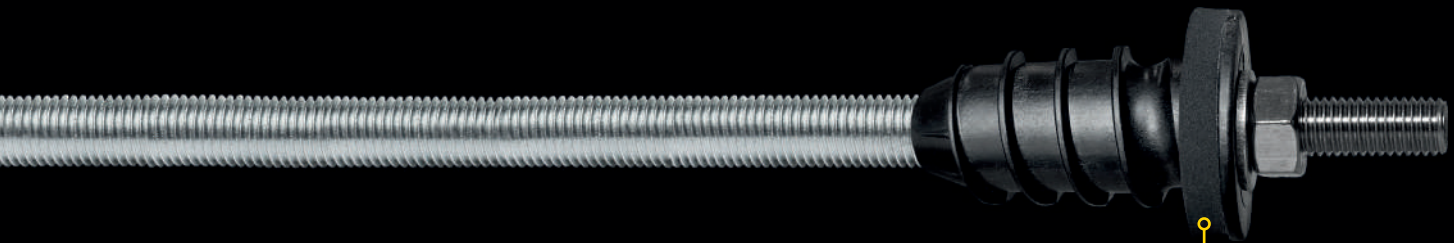

Test result

ResiTHERM® 16 & 12 are watertight against driving rain using EN 1027 (method 1A).

- Safe sealing of the facade in extreme conditions
- No moisture enters the facade
- No subsequent sealing thanks to the integrated sealing washer



Integrated weather-resistant EPDM-sealing washer, pre-assembled



How to save time?

ResiTHERM® 16 & 12 compared to other systems

Fastest mounting process

1

Drill a hole

2

**Cut the ResiTHERM®
16 or 12 to length**

3

**Fill the drill hole
with injection mortar**

4

**Screw in the ResiTHERM®
until the sealing is pressed
against the plaster**
(Details on page 12)

Excellent product design for a time-saving mounting



Pre-assembled

- Correct coordination of the product components
- No time loss for assembly of the product
- Easy mounting process

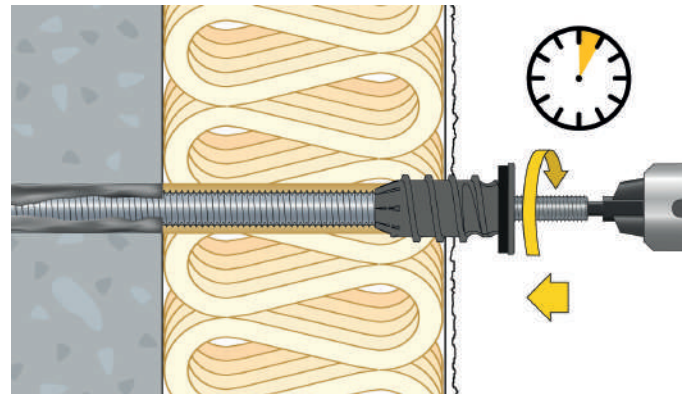

Self-cutting

- Black thermal separation module screws itself automatically through the plaster
- No need for pre-drilling in the insulation

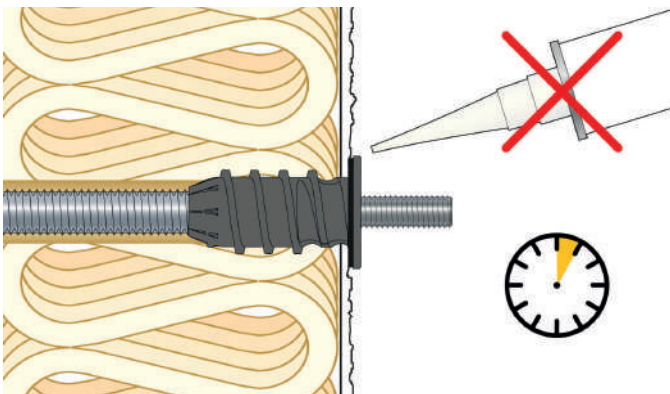

Self-sealing

- No additional sealing required, thanks to the integrated, ageing- and weather-resistant sealing washer under the head
- You save one mounting step

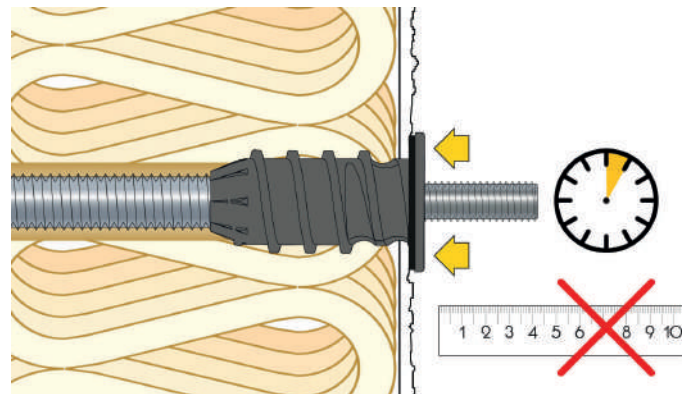

Easy to install

- No measuring of the correct setting depth
- The head with the integrated sealing disk rests on the plaster and prevents it from slipping into the drill hole

Content of the sets

ResiTHERM® Set of 2 and set of 20

One set of 2 includes

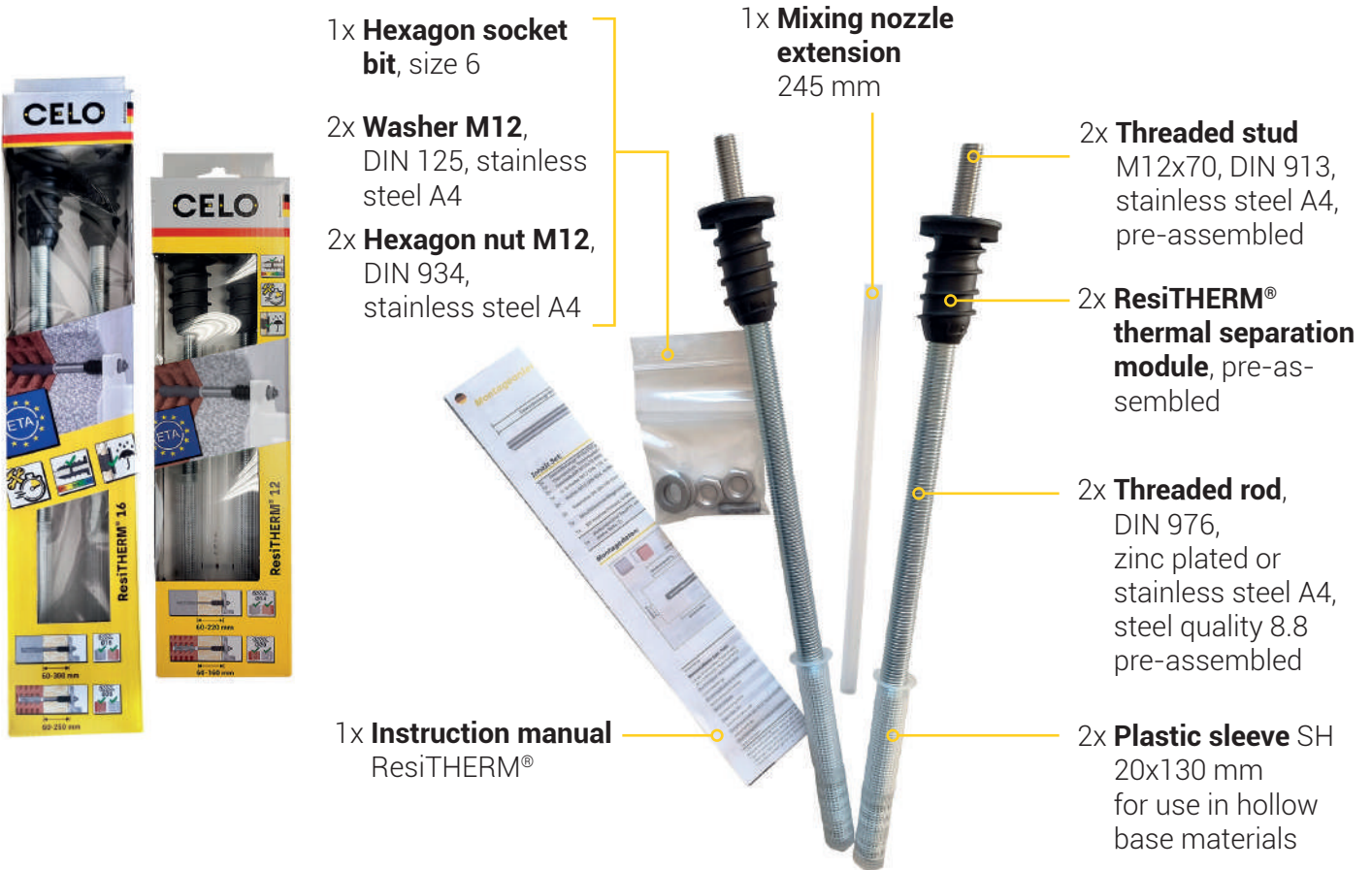

One set of 20 includes

- 20x **ResiTHERM® thermal separation module**, pre-assembled
- 20x **Threaded rod**, DIN 976, galvanized or stainless steel A4, pre-assembled
- 20x **Threaded stud** M12x70, DIN 913, stainless steel A4, pre-assembled
- 20x **Hexagon nut M12**, DIN 934 A4, stainless steel A4
- 20x **Washer M12**, DIN 125, stainless steel A4
- 1x **Hexagon socket bit**, size 6
- 8x **Mixing nozzle extension** 245 mm
- 20x **Plastic sleeve SH** 20x130 mm
- 4x **Instruction manual** ResiTHERM®



Assortment

ResiTHERM® 16 & 12

ResiTHERM® 16 Sets



ResiTHERM® 8.8 16/250 M12

Type	Art-No	Anchor rod in the wall Ø metric rod x length [mm]	Material of anchor rod in the wall	Length L [mm]	Connection thread	Thickness of insulation e [mm]		[set]	[sets]
Set ResiTHERM® 8.8 16/250 M12	9250RTH162	M16 x 350	zinc plated	385	M12	Concrete: 60 - 300 Solid brick, Aerated concrete: 60 - 280 Hollow brick: 60 - 250		1 set (2 pieces)	8
Set ResiTHERM® 8.8 16/250 M12	9250RTH1620	M16 x 350	zinc plated	385	M12			1 set (20 pieces)	-
Set ResiTHERM® A4 16/250 M12	9X250RTH162	M16 x 350		385	M12			1 set (2 pieces)	8
Set ResiTHERM® A4 16/250 M12	9X250RTH1620	M16 x 350		385	M12			1 set (20 pieces)	-

ResiTHERM® 12 Sets



ResiTHERM® 8.8 12/160 M12

Type	Art-No	Anchor rod in the wall Ø metric rod x length [mm]	Material of anchor rod in the wall	Length L [mm]	Connection thread	Thickness of insulation e [mm]		[set]	[sets]
Set ResiTHERM® 8.8 12/160 M12	9160RTH122	M12 x 260	zinc plated	295	M12	Concrete: 60 - 220 Solid brick, Aerated concrete: 60 - 190 Hollow brick: 60 - 160		1 set (2 pieces)	8
Set ResiTHERM® 8.8 12/160 M12	9160RTH1220	M12 x 260	zinc plated	295	M12			1 set (20 pieces)	-
Set ResiTHERM® A4 12/160 M12	9X160RTH122	M12 x 260		295	M12			1 set (2 pieces)	8
Set ResiTHERM® A4 12/160 M12	9X160RTH1220	M12 x 260		295	M12			1 set (20 pieces)	-

Mounting ResiTHERM® 16 & 12



Mounting in concrete

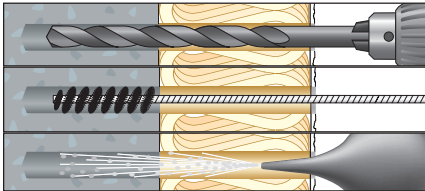

1. Drill a hole: Drill hole depth + insulation thickness
2. Clean the drill hole properly according to ETA: 4x blow - 4x brush - 4x blow

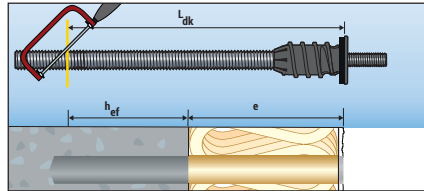

3. Cut the ResiTHERM® 16 or 12 to length: After determining the correct length, cut the threaded rod to length with a metal saw or similar.

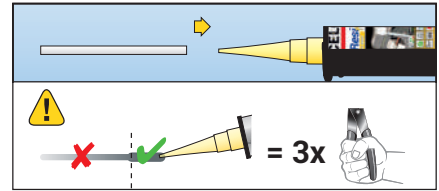

4. Attach the mixing nozzle extension MDV to the mixing nozzle MD. Squeeze out the injection mortar until the mortar has a uniform grey mixing colour - discard the pre-run of the first at least 3 strokes.

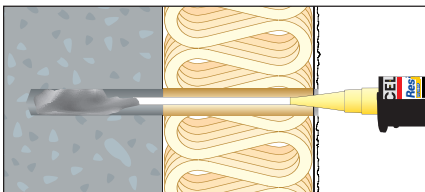

5. Fill at least 2/3 of the drill hole with composite mortar (start from the beginning). For number of strokes see mounting instructions at www.celofixings.com.
Important: Follow the installation instructions and processing time of the ResiFIX injection mortar used in accordance with the approval/assessment.

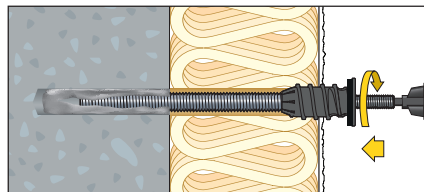

6. Screw in the ResiTHERM® 16 or 12 with the hexagon bit (included) and a cordless screwdriver until the seal is pressed against the plaster.
Note: The thermal separation module drills itself through the insulation (additional sealing is not necessary, unless the plaster is very rough)

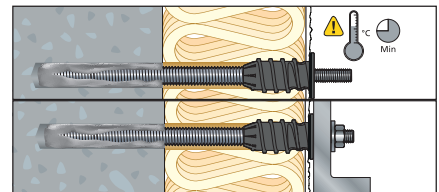

7. Observe curing time of the injection system, see cartridge label of the ResiFIX injection mortar.
8. Afterwards, the attachment can be mounted, max. torque $T_{inst} = 25 \text{ Nm}$ (ResiTHERM® 16) or 19 Nm (ResiTHERM® 12)



Mounting in masonry (hollow brick)

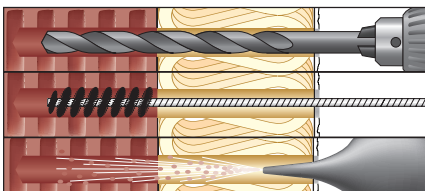

1. Drill a hole: Drill hole diameter = 20 mm. Drill hole depth $\geq 140 \text{ mm}$ + insulation thickness (incl. plaster). Observe the drilling procedure of the approval/ assessment of ResiFIX injection mortar.
Perforated bricks and aerated concrete: Rotary drilling - without impact
2. Clean the drill hole properly according to ETA: 2x blow - 2x brush - 2x blow

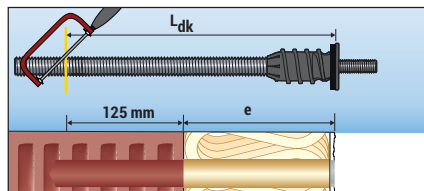

3. Cut the ResiTHERM® 16 or 12 to length: Correct length L_{dk} : Anchorage depth in plastic sleeve (125 mm) + insulation thickness e (incl. plaster) After determining the correct length, cut the threaded rod to length with a metal saw or similar.

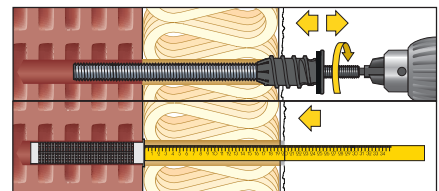

4. Enlarge the opening in the plaster for the collar of the plastic sleeve to 26 mm. To do this, briefly screw the thermal separation module in and out through the plaster for only approx. 2 thread turns or ream the plaster with a drill or drill with a bigger 26 mm drill.
5. Push the plastic sleeve into the drill hole with the help of a folding ruler or similar.

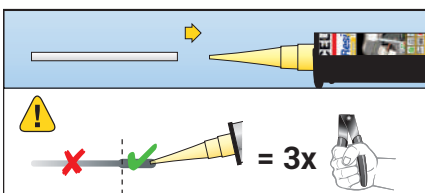

6. Attach the mixing nozzle extension MDV to the mixing nozzle MD. Squeeze out the injection mortar until the mortar has a uniform grey mixing colour - discard the pre-run of the first at least 3 strokes.

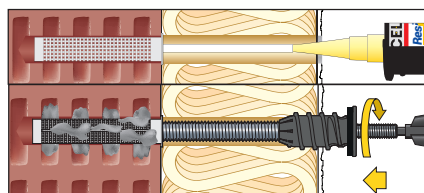

7. Fill the plastic sleeve completely with composite mortar (start from the beginning). For number of strokes see mounting instructions at www.celofixings.com
Important: Follow the installation instructions and processing time of the ResiFIX injection mortar used in accordance with the approval/assessment.
8. Screw in the ResiTHERM® 16 or 12 with the hexagon bit (included) and a cordless screwdriver until the seal is pressed against the plaster.

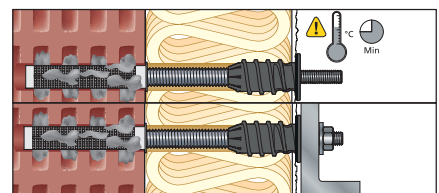

9. Observe curing time of the injection system, see cartridge label of the ResiFIX injection mortar.
10. Afterwards, the attachment can be mounted, max. torque $T_{inst} = 25 \text{ Nm}$ (ResiTHERM® 16) or 19 Nm (ResiTHERM® 12) (Observe possible deviating max. installation torque in the ETA of the injection system used)

Mounting accessories

ResiTHERM® 16 & 12

Choose your injection mortar and mounting equipment for a fast and easy installation

Injection mortar ResiFIX



Vinylester VYSF (styrene free)

Type	Art-No	Content [ml]	Mixing nozzles included [pcs]	Shelf life [months]	ETA	Box [pcs]
VY 300 SF	300VSF	280	2	18	●	12
VY 345 SF	345VSF	345	2	18	●	12
VY 410 SF	410VYSF	410	1	18	●	12



Vinylester VY ECO SF (styrene free)

Type	Art-No	Content [ml]	Mixing nozzles included [pcs]	Shelf life [months]	ETA	Box [pcs]
VY ECO 300 SF	300VYECOSF	300	2	18	●	12



Polyester PYSF (styrene free)

Type	Art-No	Content [ml]	Mixing nozzles included [pcs]	Shelf life [months]	ETA	Box [pcs]
PY 165 SF	165PSF	165	2	18	●	1
PY 300 SF	300PSF	300	1	18	●	12
PY 345 SF	345PSF	345	1	18	●	12
PY 410 SF	410PYSF	410	1	18	●	12

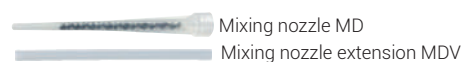

Type	Art-No	Outer-Ø [mm]	Length [mm]	Box [pcs]
MD	9MRMEA	–	215	20
MDV 10	9MDV	10	200	10
MDV 10	9500MDV	10	500	10

Mounting equipment



Type	Art-No	Suitable for ResiFIX type	Box [pcs]
APP 300	300APP	300 / 165 / 280	1
APVM	345APVM	345 / 300 / 280 / 165	1
APP 380	380APP	410	1

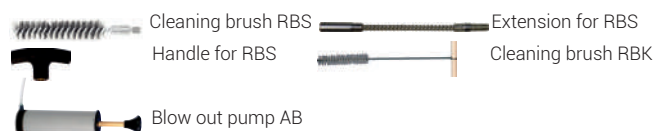

Type	Art-No	Length [mm]	Suitable for drill hole Ø [mm]	Suitable for anchor rod	Connecting thread	Box [pcs]
RBS Ø20 for concrete and masonry	9M20RBK	200	18	M16	M6	5
Extension for RBS Ø20	MRBKH	–	all	all	M6	5
Handle for RBS Ø20	MRBKV	140	all	all	M6	5
RBK Ø20 for masonry*	9PLRBK	300	20	M16	–	5
Blow out pump AB	BOP	300	8	–	–	1

* not part of the ETA assessments of the ResiFIX injection mortars

Fine-tuning accessories



Two-hole nut driver DIN 3116C for adjusting ResiTHERM® 16 & 12

Type	Art-No	Length L [mm]	Width W [mm]	Sheet thickness t _m [mm]	Suitable for	Box [pcs]	Box [pcs]
Two-hole nut driver	155253AMT	155	25	3	ResiTHERM® 16 & 12	1	15



Threaded stud adapter M12/M10, stainless steel A4 incl M10 nut and washer



Type	Art-No	Length L [mm]	Suitable for	Box [pcs]	Box [pcs]
Threaded stud adapter	X70M12M10ECT4	70	ResiTHERM® 16 & 12	4	60

Technical values

ResiTHERM® 16 & 12

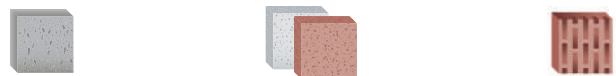
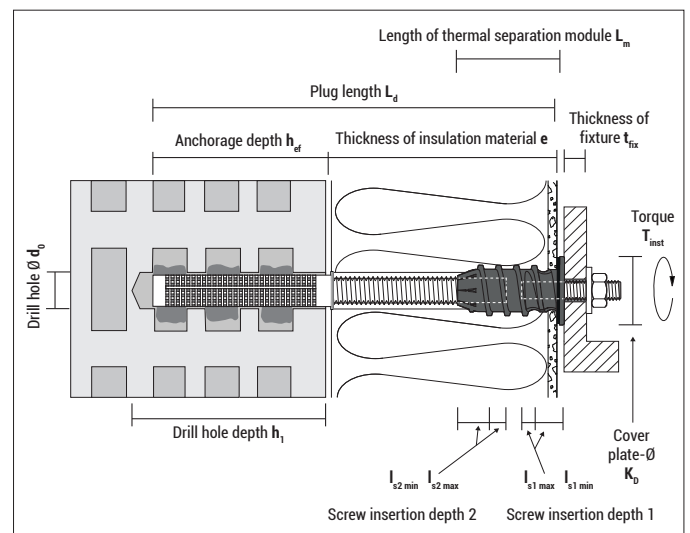
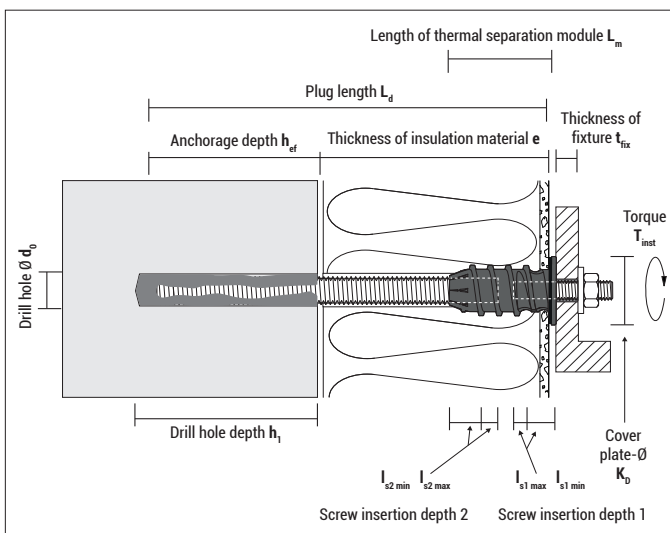
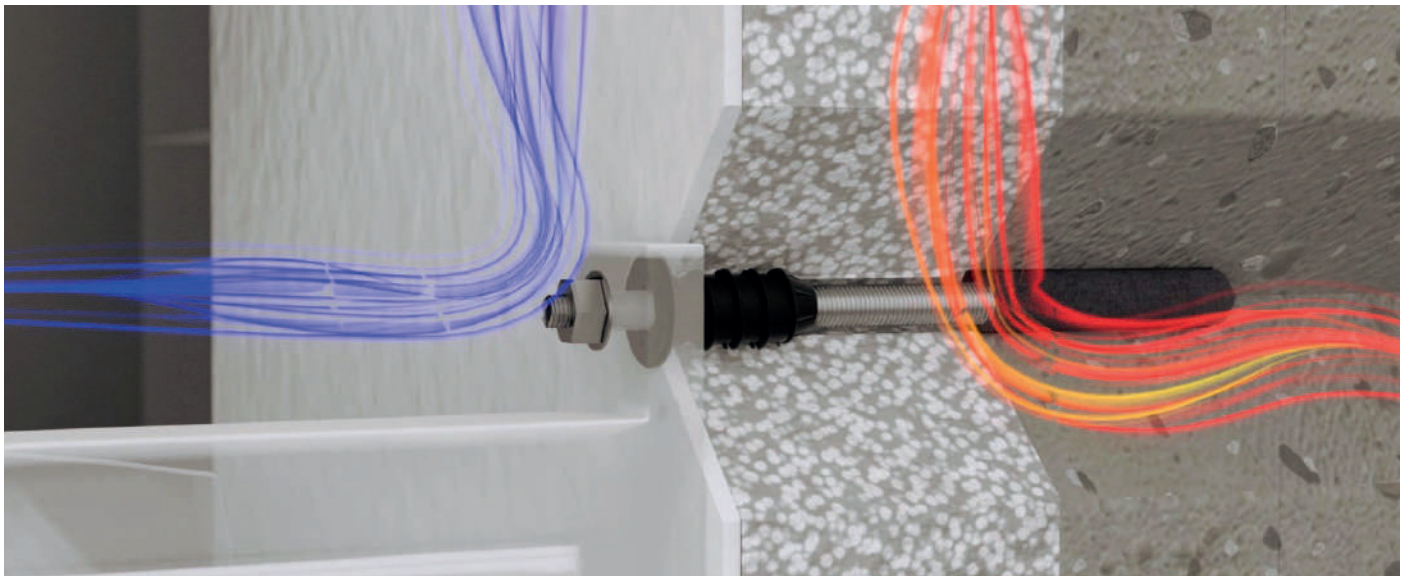

Installation parameters		Installation in concrete		Installation in aerated concrete/solid brick		Installation in perforated brick	
		ResiTHERM® 16	ResiTHERM® 12	ResiTHERM® 16	ResiTHERM® 12	ResiTHERM® 16	ResiTHERM® 12
Plug length	L_d [mm]	385 ¹⁾	295 ¹⁾	385 ¹⁾	295 ¹⁾	385 ¹⁾	295 ¹⁾
Thickness of insulation material (incl. plaster)	e [mm]	60 - max. 300	60 - max. 220	60 - max. 280	60 - max. 190	60 - max. 250	60 - max. 160
Length of thermal separation module (to lower edge of cover plate)	L_m [mm]	60	60	60	60	60	60
Diameter cover plate	K_D [mm]	42	42	42	42	42	42
Threaded rod	[mm]	M16 x 350 ¹⁾	M12 x 260 ¹⁾	M16 x 350 ¹⁾	M12 x 260 ¹⁾	M16 x 350 ¹⁾	M12 x 260 ¹⁾
Insertion depth of threaded stud	$l_{s2 \text{ min-max}}$ [mm]	24-27	24-27	24-27	24-27	24-27	24-27
Drill hole diameter	d_0 [mm]	18	14	18	14	20	20
Drill hole depth	$h_1 \geq$ [mm]	90 + e	80 + e	110 + e	110 + e	140 + e	140 + e
Anchorage depth	h_{ef} [mm]	80	70	100	100	125	125
Plastic sleeve SH		–	–	–	–	20-130	20-130
Connecting thread	[mm]	M12 ³⁾	M12 ³⁾	M12 ³⁾	M12 ³⁾	M12 ³⁾	M12 ³⁾
Insertion depth of M12 threaded stud	$l_{s1 \text{ min-max}}$ [mm]	30-34	30-34	30-34	30-34	30-34	30-34
Thickness of fixture	$t_{fix} \leq$ [mm]	24 ²⁾	24 ²⁾	24 ²⁾	24 ²⁾	24 ²⁾	24 ²⁾

¹⁾ Threaded rod has to be cut as needed.

For further technical values, see assessment of the ResiFIX injection system used.







²⁾ When using the threaded stud with length $L=70$ mm. Otherwise, a longer threaded stud or a longer metric screw can be used.

³⁾ Alternative: Threaded stud adapter M12/M10, length 70 mm, stainless steel A4, Art-No X70M12M10ECT4

Technical values

ResiTHERM® 16 & 12

Permissible tension load and pressure load ResiTHERM® 16 ¹⁾ at 24°C/40°C ²⁾

M16 anchor rod in 8.8	applied injection mortar ResiFIX VY SF acc. ETA-10/0134	applied injection mortar ResiFIX VY SF acc. ETA-15/0320				
Base material	 Concrete C20/25 ³⁾	 Solid sand-lime brick KS KS28-2,0 ³⁾	 Solid brick MZ 20-2,0 ¹⁾	 Hollow sand-lime brick KSL 12-1,4 ⁴⁾	 Hollow brick HLZ 12-1,25 ⁴⁾	 Aerated concrete AAC 2 ³⁾
Insulation thickness e	Permissible tension load N_{per}					
	[kN]	[kN]	[kN]	[kN]	[kN]	[kN]
60-300 mm	4,57	2,00	2,29	1,65	1,11	0,71
Insulation thickness e	Permissible pressure load P_{per}					
	[kN]	[kN]	[kN]	[kN]	[kN]	[kN]
60 - 220 mm	5,14	2,00	2,29	1,65	1,11	0,71
221 - 300 mm	5,14	2,00	2,29	1,65	1,11	0,71
Min. anchorage depth h_{ef}	80	100	100	130	130	100

¹⁾ Loads include the partial safety factors of the material given in the ETA as well as a partial safety factor for the actions of $\gamma_F = 1.4$.







²⁾ For other temperature ranges see ETA-assessment.

³⁾ In full material the tension load resistance can be used also for the pressure load resistance.

⁴⁾ In hollow materials the pressure load resistance specified in the ETA can be applied, if the setting depth is deep enough to include minimum 5 webs with the injection mortar. If the setting depth is lower and does not include 5 webs, then the pressure load resistance must be reduced.

1 kN = 100 kg

Permissible tension load and pressure load ResiTHERM® 12 ¹⁾ at 24°C/40°C ²⁾

M12 anchor rod in 8.8	applied injection mortar ResiFIX VY SF acc. ETA-10/0134	applied injection mortar ResiFIX VY SF acc. ETA-15/0320				
Base material	 Concrete C20/25 ³⁾	 Solid sand-lime brick KS KS28-2,0 ³⁾	 Solid brick MZ 20-2,0 ¹⁾	 Hollow sand-lime brick KSL 12-1,4 ⁴⁾	 Hollow brick HLZ 12-1,25 ⁴⁾	 Aerated concrete AAC 2 ³⁾
Insulation thickness e	Permissible tension load N_{per}					
	[kN]	[kN]	[kN]	[kN]	[kN]	[kN]
60 - 220 mm	5,14	2,00	2,00	1,65	1,11	0,71
Insulation thickness e	Permissible pressure load P_{per}					
	[kN]	[kN]	[kN]	[kN]	[kN]	[kN]
60 - 120 mm	5,14	2,00	2,00	1,65	1,11	0,71
121 - 160 mm	5,14	2,00	2,00	1,65	1,11	0,71
161 - 220 mm	2,86	2,00	2,00	1,65	1,11	0,71
Min. anchorage depth h_{ef}	70	100	100	130	130	100

¹⁾ Loads include the partial safety factors of the material given in the ETA as well as a partial safety factor for the actions of $\gamma_F = 1.4$.

²⁾ For other temperature ranges see ETA-assessment.

³⁾ In full material the tension load resistance can be used also for the pressure load resistance.

⁴⁾ In hollow materials the pressure load resistance specified in the ETA can be applied, if the setting depth is deep enough to include minimum 5 webs with the injection mortar. If the setting depth is lower and does not include 5 webs, then the pressure load resistance must be reduced.

1 kN = 100 kg

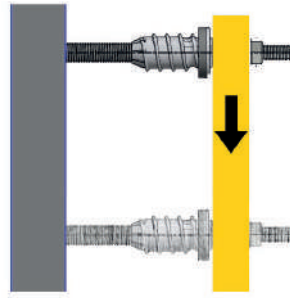

Maximum shear loads V¹⁾ at max. 3 or 5 mm displacement per ResiTHERM® if the free outer end of the ResiTHERM® 16 & 12 is not freely rotatable (e.g. connected double fixing) at 24°C/40°C²⁾

Not free rotatable anchor rod M16 in 8.8	applied injection mortar ResiFIX VY SF acc. ETA-10/0134						applied injection mortar ResiFIX VY SF acc. ETA-15/0320					
Base material	Concrete C20/25	Solid sand-lime brick KS KS28-2,0	Solid brick MZ 20-2,0	Hollow sand-lime brick KSL 12-1,4	Hollow brick HLZ 12-1,25	Aerated concrete AAC 2						

if displacement is 3 mm

Insulation thickness e [mm]	Maximum shear load V [kN]											
	ResiTHERM® 16		ResiTHERM® 12		ResiTHERM® 16		ResiTHERM® 12		ResiTHERM® 16		ResiTHERM® 12	
	16	12	16	12	16	12	16	12	16	12	16	12
60	2,14	1,43	2,00	1,43	2,14	1,43	1,53	1,43	2,14	1,43	0,89	0,89
80	2,14	1,43	2,00	1,43	2,14	1,43	1,53	1,43	2,14	1,43	0,89	0,89
100	2,14	1,43	2,00	1,43	2,14	1,43	1,53	1,43	2,14	1,43	0,89	0,89
120	1,84	1,01	1,84	1,01	1,84	1,01	1,53	1,01	1,84	1,01	0,89	0,89
140	1,49	0,85	1,49	0,85	1,49	0,85	1,49	0,85	1,49	0,85	0,89	0,85
160	1,15	0,69	1,15	0,69	1,15	0,69	1,15	0,69	1,15	0,69	0,89	0,69
180	0,80	0,54	0,80	0,54	0,80	0,54	0,80	0,54	0,80	0,54	0,80	0,54
200	0,71	0,38	0,71	0,38	0,71	0,38	0,71	0,38	0,71	0,38	0,71	0,38
220	0,61	0,22	0,61	0,22	0,61	0,22	0,61	0,22	0,61	0,22	0,61	0,22
240	0,51	-	0,51	-	0,51	-	0,51	-	0,51	-	0,51	-
250	0,47	-	0,47	-	0,47	-	0,47	-	0,47	-	0,47	-
260	0,42	-	0,42	-	0,42	-	0,42	-	0,42	-	0,42	-
280	0,32	-	0,32	-	0,32	-	0,32	-	0,32	-	0,32	-
300	0,22	-	0,22	-	0,22	-	0,22	-	0,22	-	0,22	-

if displacement is 5 mm

Insulation thickness e [mm]	Maximum shear load V [kN]											
	ResiTHERM® 16		ResiTHERM® 12		ResiTHERM® 16		ResiTHERM® 12		ResiTHERM® 16		ResiTHERM® 12	
	16	12	16	12	16	12	16	12	16	12	16	12
60	2,14	1,43	2,00	1,43	2,14	1,43	1,53	1,43	2,14	1,43	0,89	0,89
80	2,14	1,43	2,00	1,43	2,14	1,43	1,53	1,43	2,14	1,43	0,89	0,89
100	2,14	1,43	2,00	1,43	2,14	1,43	1,53	1,43	2,14	1,43	0,89	0,89
120	2,14	1,43	2,00	1,43	2,14	1,43	1,53	1,43	2,14	1,43	0,89	0,89
140	2,14	1,29	2,00	1,29	2,14	1,29	1,53	1,29	2,14	1,29	0,89	0,89
160	1,76	1,06	1,76	1,06	1,76	1,06	1,53	1,06	1,76	1,06	0,89	0,89
180	1,27	0,82	1,27	0,82	1,27	0,82	1,27	0,82	1,27	0,82	0,89	0,82
200	1,12	0,59	1,12	0,59	1,12	0,59	1,12	0,59	1,12	0,59	0,89	0,59
220	0,97	0,35	0,97	0,35	0,97	0,35	0,97	0,35	0,97	0,35	0,89	0,35
240	0,82	-	0,82	-	0,82	-	0,82	-	0,82	-	0,82	-
250	0,74	-	0,74	-	0,74	-	0,74	-	0,74	-	0,74	-
260	0,67	-	0,67	-	0,67	-	0,67	-	0,67	-	0,67	-
280	0,51	-	0,51	-	0,51	-	0,51	-	0,51	-	0,51	-
300	0,36	-	0,36	-	0,36	-	0,36	-	0,36	-	0,36	-

Thickness of structural part	h_{min} [mm]	112	115	115	195	195	240
Min. edge distance	c_{min} [mm]	80	60	60	60	50	50
Min. spacing	s_{min} [mm]	80	75	65	120	50	50
Torque	T_{inst} [Nm]	25 ³⁾	19 ³⁾	15 ³⁾	10 ³⁾	8 ³⁾	10 ³⁾

All values are based on ResiFIX VY SF
¹⁾ Intermediate values can be interpolated/ Values are limited due to the maximum shear load capacity.
²⁾ For other temperature ranges see ETA-assessment.
³⁾ Depending on the base material, see ETA of ResiFIX injection mortar
 1 kN = 100 kg

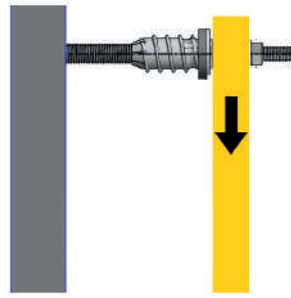

Maximum shear loads V ¹⁾ at max. 3 or 5 mm displacement per ResiTHERM® if the free outer end of the ResiTHERM® 16 & 12 is freely rotatable at 24°C/40°C²⁾

Free rotatable anchor rod M16 in 8.8	applied injection mortar ResiFIX VY SF acc. ETA-10/0134						applied injection mortar ResiFIX VY SF acc. ETA-15/0320					
	Concrete C20/25		Solid sand-lime brick KS KS28-2,0		Solid brick MZ 20-2,0		Hollow sand-lime brick KSL 12-1,4		Hollow brick HLZ 12-1,25		Aerated concrete AAC 2	
Base material												

if displacement is 3 mm

Insulation thickness e [mm]	Maximum shear load V [kN]											
	ResiTHERM® 16		ResiTHERM® 12		ResiTHERM® 16		ResiTHERM® 12		ResiTHERM® 16		ResiTHERM® 12	
	16	12	16	12	16	12	16	12	16	12	16	12
60	1,59	1,25	1,59	1,25	1,59	1,25	1,53	1,25	1,59	1,25	0,89	0,89
80	1,38	0,85	1,38	0,85	1,38	0,85	1,38	0,85	1,38	0,85	0,89	0,85
100	1,06	0,61	1,06	0,61	1,06	0,61	1,06	0,61	1,06	0,61	0,89	0,61
120	0,75	0,36	0,75	0,36	0,75	0,36	0,75	0,36	0,75	0,36	0,75	0,36
140	0,63	0,31	0,63	0,31	0,63	0,31	0,63	0,31	0,63	0,31	0,63	0,31
160	0,52	0,25	0,52	0,25	0,52	0,25	0,52	0,25	0,52	0,25	0,52	0,25
180	0,41	0,20	0,41	0,20	0,41	0,20	0,41	0,20	0,41	0,20	0,41	0,20
200	0,36	0,14	0,36	0,14	0,36	0,14	0,36	0,14	0,36	0,14	0,36	0,14
220	0,31	0,09	0,31	0,09	0,31	0,09	0,31	0,09	0,31	0,09	0,31	0,09
240	0,26	–	0,26	–	0,26	–	0,26	–	0,26	–	0,26	–
250	0,24	–	0,24	–	0,24	–	0,24	–	0,24	–	0,24	–
260	0,21	–	0,21	–	0,21	–	0,21	–	0,21	–	0,21	–
280	0,17	–	0,17	–	0,17	–	0,17	–	0,17	–	0,17	–
300	0,12	–	0,12	–	0,12	–	0,12	–	0,12	–	0,12	–

if displacement is 5 mm

Insulation thickness e [mm]	Maximum shear load V [kN]											
	ResiTHERM® 16		ResiTHERM® 12		ResiTHERM® 16		ResiTHERM® 12		ResiTHERM® 16		ResiTHERM® 12	
	16	12	16	12	16	12	16	12	16	12	16	12
60	1,86	1,43	1,86	1,43	1,86	1,43	1,53	1,43	1,86	1,43	0,89	0,89
80	1,86	1,35	1,86	1,35	1,86	1,35	1,53	1,35	1,86	1,35	0,89	0,89
100	1,66	0,96	1,66	0,96	1,66	0,96	1,53	0,96	1,66	0,96	0,89	0,89
120	1,19	0,56	1,19	0,56	1,19	0,56	1,19	0,56	1,19	0,56	0,89	0,56
140	1,00	0,48	1,00	0,48	1,00	0,48	1,00	0,48	1,00	0,48	0,89	0,48
160	0,82	0,40	0,82	0,40	0,82	0,40	0,82	0,40	0,82	0,40	0,82	0,40
180	0,64	0,31	0,64	0,31	0,64	0,31	0,64	0,31	0,64	0,31	0,64	0,31
200	0,56	0,23	0,56	0,23	0,56	0,23	0,56	0,23	0,56	0,23	0,56	0,23
220	0,49	0,15	0,49	0,15	0,49	0,15	0,49	0,15	0,49	0,15	0,49	0,15
240	0,42	–	0,42	–	0,42	–	0,42	–	0,42	–	0,42	–
250	0,38	–	0,38	–	0,38	–	0,38	–	0,38	–	0,38	–
260	0,34	–	0,34	–	0,34	–	0,34	–	0,34	–	0,34	–
280	0,27	–	0,27	–	0,27	–	0,27	–	0,27	–	0,27	–
300	0,19	–	0,19	–	0,19	–	0,19	–	0,19	–	0,19	–

Thickness of structural part	h_{min} [mm]	112	115	115	195	195	240
Min. edge distance	c_{min} [mm]	80	60	60	60	50	50
Min. spacing	s_{min} [mm]	80	75	65	120	50	50
Torque	T_{inst} [Nm]	25 ³⁾	19 ³⁾	15 ³⁾	10 ³⁾	8 ³⁾	10 ³⁾

All values are based on ResiFIX VY SF

¹⁾ Intermediate values can be interpolated/ Values are limited due to the maximum shear load capacity.

²⁾ For other temperature ranges see ETA-assessment.

³⁾ Depending on the base material, see ETA of ResiFIX injection mortar

1 kN = 100 kg

ResiTHERM® 37

The ETA-approved distance mounting system for fixing heavy loads to insulated hollow bricks – without thermal bridges



Reliable, durable fastening **with ETA** (European Technical Assessment / Approval)

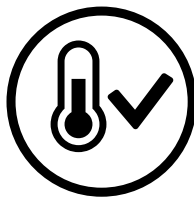

Effective thermal separation prevents cold bridges



High-quality materials such as A4 stainless steel and glass-fibre reinforced UV-resistant nylon



Manufactured in Germany (Aichach, Bavaria)



Components and advantages

ResiTHERM® 37

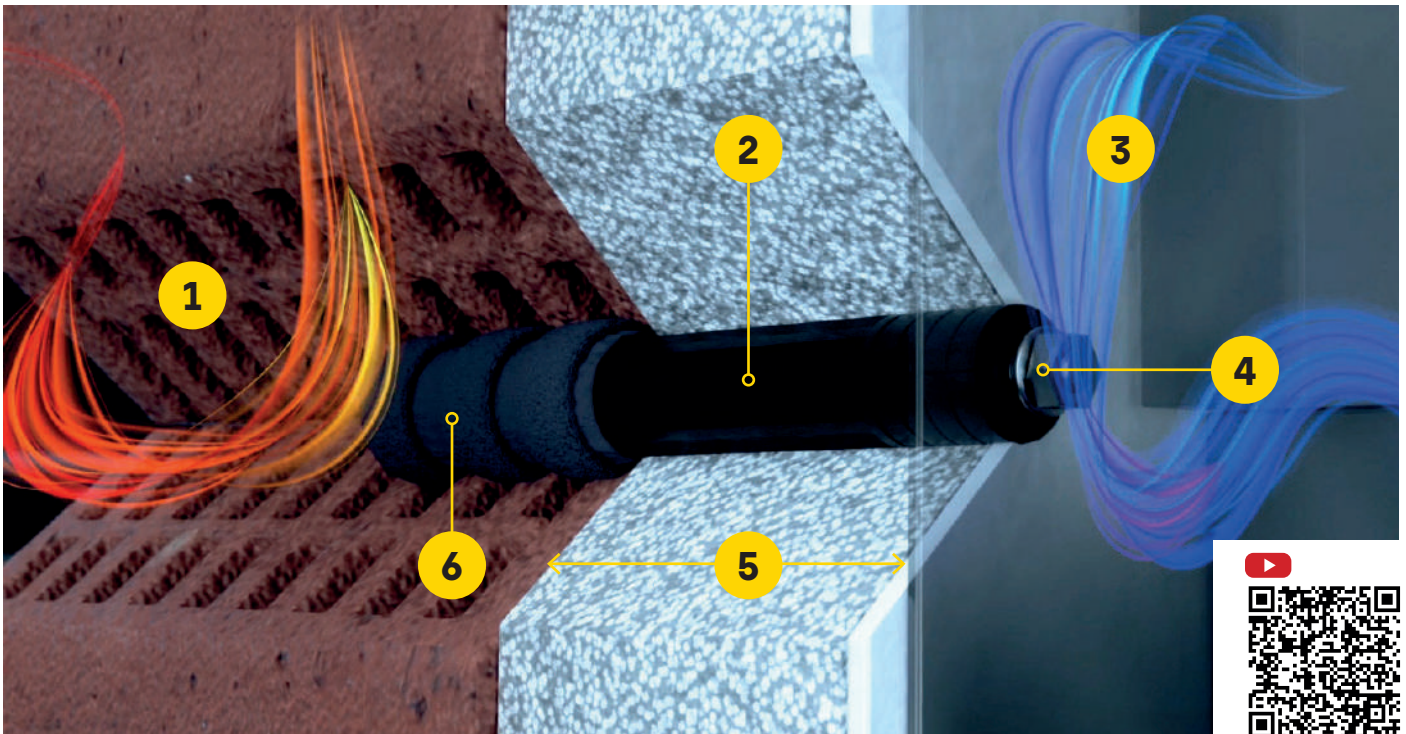

1 The perfect ETA-approved solution

for distance installations in hollow bricks with outstanding high load values, suitable for hollow bricks, aerated concrete and to a limited extent for hollow sand-lime brick

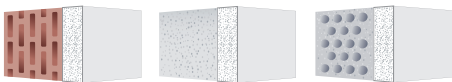

2 Available in three standard lengths

Ready to use products for different insulation thicknesses



ResiTHERM® 37/200



ResiTHERM® 37/160



ResiTHERM® 37/120

3 Excellent thermal separation

almost no thermal bridge

4 Heavy-duty system

for fastening of

- awnings
- canopies
- french balconies
- railings
- satellite dishes etc.

in ETICS

5 Suitable for insulation thicknesses up to 200 mm

ResiTHERM® 37/200

for insulation thicknesses
160-200 mm

ResiTHERM® 37/160

for insulation thicknesses
120-160 mm

ResiTHERM® 37/120

for insulation thicknesses
80-120 mm

For non-insulated facades the heavy-duty sleeve ResiTHERM® 37/0 can be used.

6 Tested

in combination with the CELO injection system ResiFIX VYSF

Content of the sets

ResiTHERM® 37

One set of 2 includes

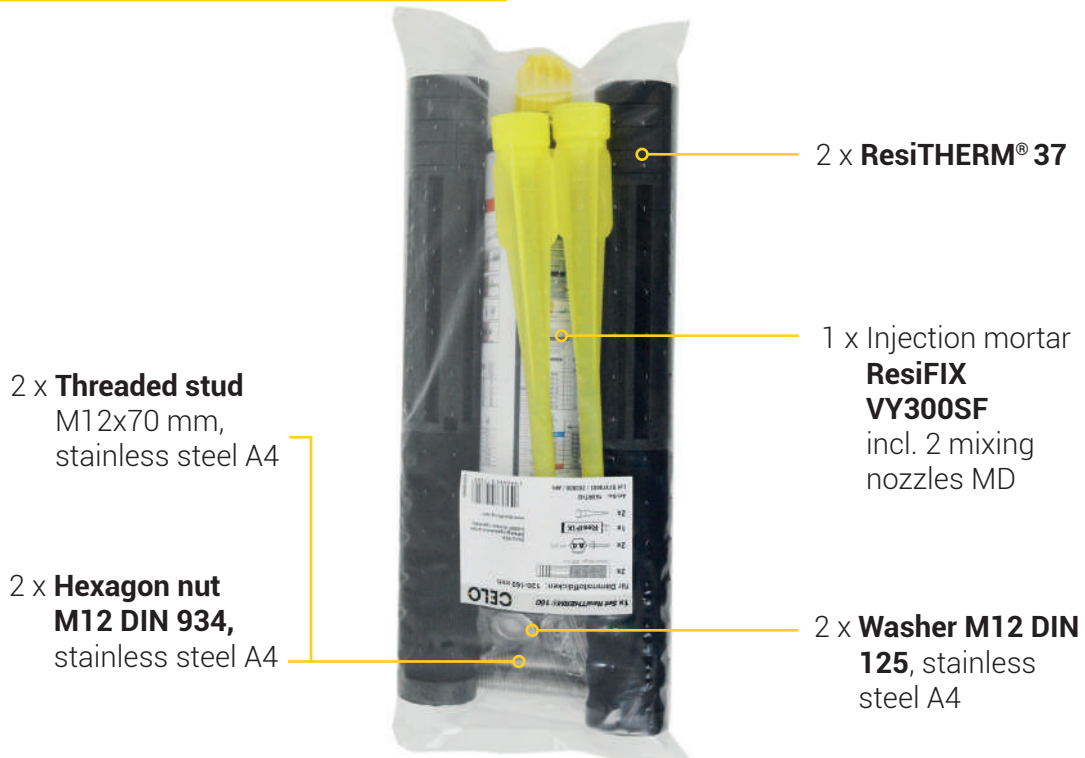

2 x **Threaded stud**
M12x70 mm,
stainless steel A4

2 x **Hexagon nut**
M12 DIN 934,
stainless steel A4

2 x **ResiTHERM® 37**

1 x Injection mortar
ResiFIX
VY300SF
incl. 2 mixing
nozzles MD

2 x **Washer M12 DIN**
125, stainless
steel A4

One starter set includes



4x **ResiTHERM® 37**

4x **Threaded stud M12x70 mm**, stainless steel A4

4x **Washer M12 DIN 125**, stainless steel A4

4x **Hexagon nut M12 DIN 934**, stainless steel A4

2x **Injection mortar ResiFIX VY300SF**

incl. 4x mixing nozzle MD

1x **Drilling aid** for core bit

1x **Core bit** Ø 39 x 220 mm

1x **Adapter shank** hexagon, M16, 100 mm for core bit

1x **Adapter shank** hexagon, M16, 200 mm for core bit

1x **Sealing adhesive StickFX XP white**, MS Polymer

1x **Manual dispenser** APVM

50x **Distance washer DIN 9021** for M12 (13x37x3 mm)

1x Pair work gloves

Assortment

ResiTHERM® 37

ResiTHERM® 37 starter set



Starter set ResiTHERM® 37 in universal box (30 x 40 x 23 cm)

Type	Art-No	ResiTHERM® 37	Art-No Accessories	Accessories		
SYS120RTH4	Starter set RTH 120	4x ResiTHERM® 37/120 M12	–	4x Threaded stud M12x70 mm, stainless steel A4 4x Washer M12 DIN 125, stainless steel A4 4x Hexagon nut M12 DIN 934, stainless steel A4		1
SYS160RTH4	Starter set RTH 160	4x ResiTHERM® 37/160 M12	300VSF 39ABH 39220BST 100M16AD 200M16AD BL290MSXP	2x Injection mortar ResiFIX VY300SF incl. 4x Mixing nozzle MD 1x Drilling aid for core bit 1x Core bit Ø 39 x 220 mm 1x Adapter shank hexagon, M16, 100 mm for core bit 1x Adapter shank hexagon, M16, 200 mm for core bit 1x StickFX XP white, MS Polymer		1
SYS200RTH4	Starter set RTH 200	4x ResiTHERM® 37/200 M12	345APVM 129021AS –	1x Manual dispenser APVM 50x Distance washer DIN 9021 for M12 (13x37x3 mm) 1 pair work gloves		1

ResiTHERM® 37 may be cut up to 40 mm if needed.

ResiTHERM® 37 sets



ResiTHERM® 37/200 M12

Type	Art-No	ResiTHERM® 37 type	Length L [mm]	Thickness of insulation material $h_p^{1)}$ [mm]			
RTH 200	200RTH2	ResiTHERM® 37/200 M12	325	160 - 200		1	10

¹⁾ResiTHERM® 37 may be cut up to 40 mm if needed.

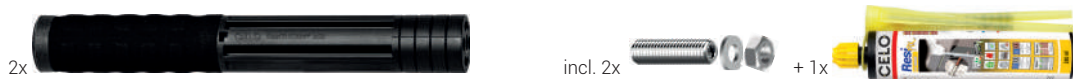

ResiTHERM® 37/160 M12 for insulation thicknesses 120 - 160 mm

Type	Art-No	ResiTHERM® 37 type	Length L [mm]	Thickness of insulation material $h_p^{1)}$ [mm]			
RTH 160	160RTH2	ResiTHERM® 37/160 M12	285	120 - 160		1	10

¹⁾ResiTHERM® 37 may be cut up to 40 mm if needed.

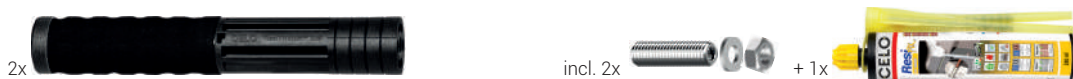

ResiTHERM® 37/120 M12 for insulation thicknesses 80 - 120 mm

Type	Art-No	ResiTHERM® 37 type	Length L [mm]	Thickness of insulation material $h_p^{1)}$ [mm]			
RTH 120	120RTH2	ResiTHERM® 37/120 M12	245	80 - 120		1	10

¹⁾ResiTHERM® 37 may be cut up to 40 mm if needed.

Mounting ResiTHERM® 37 in hollow brick



- Put drilling aid on core bit; drill with cordless screwdriver (without impact) through the insulation material up to the hollow brick wall (remove drilling aid after the first 10 mm)
- Measure the thickness of the insulation and cut ResiTHERM® 37 if needed (max. 40 mm)
- Put drilling aid on core bit and drill min. 130 mm into the hollow brick wall (remove drilling aid after the first 10 mm)
- Clean hole
- Press ResiTHERM® 37 onto mixing nozzle and push it carefully into the drill hole
- Fill ResiTHERM® 37 with injection system ResiFIX; the end of the filling process can be clearly felt
- Respect curing time
- Fill annular gap with sealant StickFX XP, MS Polymer
- Install fixture $T_{\text{inst}} \leq 20 \text{ Nm}$

Isothermic profile

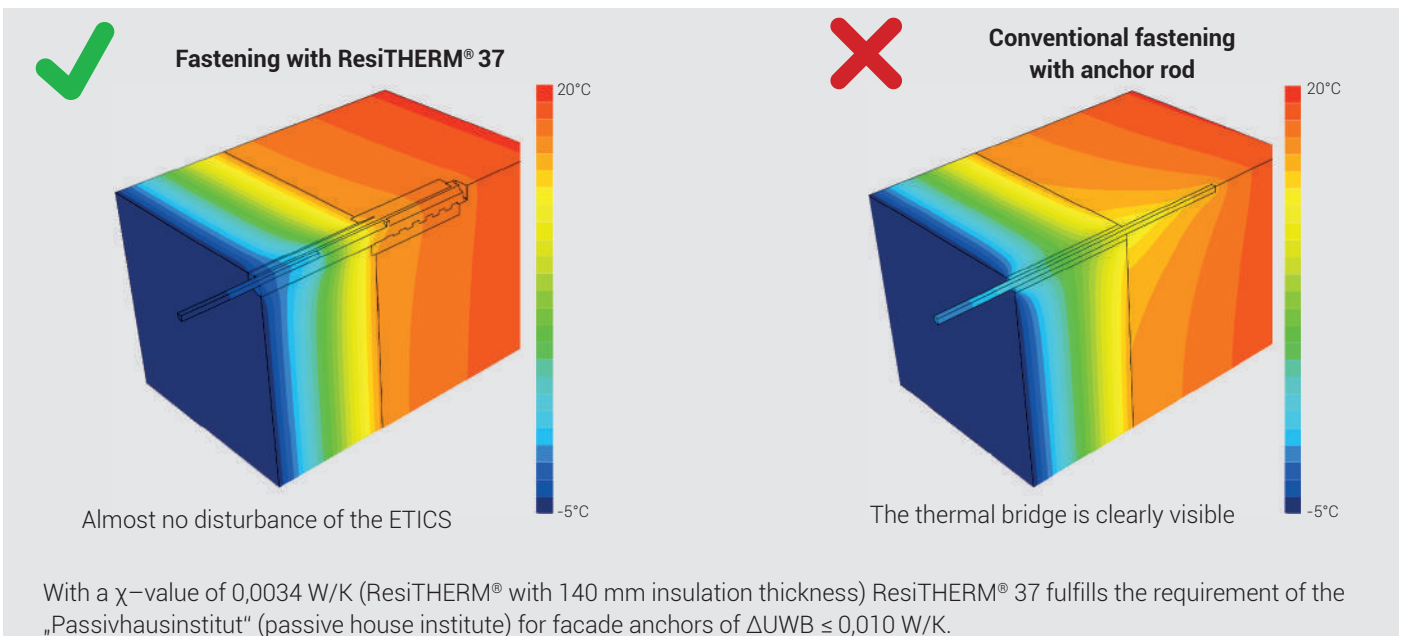

Mounting accessories

ResiTHERM® 16 & 12



Core bit for perforated brick BST



Drilling aid for core bit ABH





Core bit BST and drilling aid ABH for core bit for ResiTHERM®

Type	Art-No	Diameter d [mm]	Length L [mm]	Connecting thread	 [pcs]	 [pcs]
BST 39 x 220	39220BST	39	220	M16	1	-
ABH	39ABH	35	60	-	1	-

 AD 100

 AD 200

Adapter shank AD hexagon for core bit BST for ResiTHERM®

Type	Art-No	Length L [mm]	Connecting thread	Shank for drilling machine	Insulation thickness [mm]	 [pcs]	 [pcs]
AD 100	100M16AD	100	M16	hexagon	≤ 160	1	-
AD 200	200M16AD	200	M16	hexagon	160 - 260	1	-



Vinylester VYSF (styrene free)

Type	Art-No	Content [ml]	Mixings nozzles included [pcs]	 [pcs]
VY 300 SF	300VSF	280	2	12





StickFX Professional all-purpose adhesive XP

Type	Art-No	Content [ml]	Colour	Description	€ / pc	 [pcs]
XP white	BL290MSXP	290	white	All-purpose adhesive, fills gaps		12



Distance washer AS Polyamid, DIN 9021 for M12

Type	Art-No	Outer Ø [mm]	Disc hole Ø [mm]	Height H [mm]	€ / 100 pcs	 [pcs]	 [pcs]
AS	129021AS	37	13	3		50	-

To use as a distance washer for relining (if needed).



APVM

Manual dispenser APVM

Type	Art-No	Suitable for ResiFIX Type	€ / 100 pc	 [pcs]
APVM	345APVM	345 / 300 / 280 / 165		1

Manual dispenser APVM is recommended to read the scale units of ResiFIX VY (outer rod serves as a pointer).



Blow out pump AB

Type	Art-No	Tube-Ø [mm]	€ / pc	 [pcs]	 [pcs]
AB	BOP	8		1	-



Technical data

ResiTHERM® 37



Spacing and edge distance

ResiTHERM® 37/120, 37/160, 37/200		HLZ 12	HLZ 6
Minimum spacing	S_{min} [mm]	77 ¹⁾	77 ¹⁾
Minimum edge distance	C_{min} [mm]	125	125
Minimum thickness of structural part	h_{min} [mm]	240	300

¹⁾ Spacing of 77 mm (standard awning console).

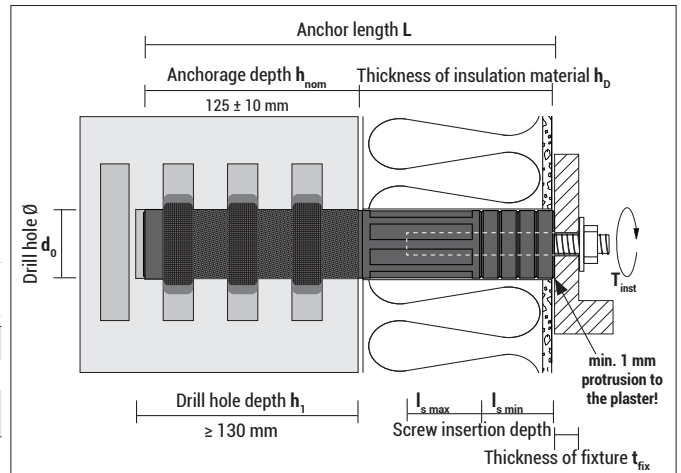

Installation parameters

		ResiTHERM® 37/120	ResiTHERM® 37/160	ResiTHERM® 37/200
Anchor length	L_d [mm]	245	285	325
Thickness of insulation material (incl. external plaster)	h_D [mm]	60 ¹⁾ - 120	120 ¹⁾ - 160	160 ¹⁾ - 200
Anchor Ø	d_{nom} [mm]	37		
Drill hole Ø	d_0 [mm]	39 - 40		
Drill hole depth	$h_1 \geq$ [mm]	130		
Anchorage depth	h_{nom} [mm]	125 ± 10 ²⁾		
Connecting thread	[mm]	M12		
Screw insertion depth of M12 threaded stud	$h_{s,min-max}$ [mm]	35 - 80		
Thickness of fixture	$t_{fix} \leq$ [mm]	22 ³⁾		
Ø of clearance hole in fixture	$d_f \geq$ [mm]	13		
Required volume of ResiFIX VY per ResiTHERM® 37	[ml]	ca. 140		
Installation torque for mounting the fixture	$T_{inst} \leq$ [Nm]	20		

¹⁾ ResiTHERM® 37 may be cut up to 40 mm if needed. ResiTHERM® 37/120 M12: If thickness of insulation material is 60 mm, set 20 mm deeper.

²⁾ Minimum anchorage depth of 115 mm is possible (see ETA assessment)

³⁾ When using a threaded stud with L=70 mm. Otherwise a longer threaded stud or a longer metric screw can be used.

Loads and displacements/deflections ResiTHERM® 37: approved system with injection system ResiFIX VY SF

Building material	System	Thickness of insulation material [mm]	Recommended loads ¹⁾	Deflection at recommended load*
Permissible tension load			N_{per} [kN]	$\delta_{v0} / \delta_{v\infty}$ [mm]
Hollow brick T1.0-240 HLZ 12 (Format 12 DF)	Single fastening	all	1,71	0,60/ 1,30
Hollow brick T10-300 HLZ 6 (Format 10 DF)	Single fastening	all	0,86	0,60/ 1,20
Aerated concrete AAC2-0,35 ²⁾	Single fastening	all	1,21	0,14/ 0,28
Aerated concrete AAC4-0,55 ²⁾	Single fastening	all	2,12	0,32/ 0,64
Permissible pressure load			F_{per} [kN]	$\delta_{F0} / \delta_{F\infty}$ [mm]
Hollow brick T1.0-240 HLZ 12 (Format 12 DF)	Single fastening	all	1,71	0,60/ 1,30
Hollow brick T10-300 HLZ 6 (Format 10 DF)	Single fastening	all	0,86	0,60/ 1,20
Permissible shear load			V_{per} [kN]	$\delta_{v0} / \delta_{v\infty}$ [mm] ⁴⁾
Hollow brick T1.0-240 HLZ 12 (Format 12 DF)	Single fastening	0	0,86	0,20/ 0,30
		120	0,34	2,00/ 4,10
		160	0,34	2,10/ 4,30
	Double fastening ³⁾	0	0,51	0,60/ 1,20
		120	0,43	1,60/ 3,20
		160	0,34	0,70/ 1,40
Hollow brick T10-300 HLZ 6 (Format 10 DF)	Single fastening	0	0,43	0,00/ 0,10
		120	0,26	1,30/ 2,60
		160	0,26	1,70/ 2,50
	Double fastening ³⁾	0	0,17	2,00/ 4,00
		120	0,17	0,10/ 0,20
		160	0,11	0,20/ 0,30
200	0,11	0,20/ 0,30		
200	0,09	0,30/ 0,50		

* Movement of ResiTHERM® 37 in load direction at permissible load.

¹⁾ Recommended loads include the partial safety factor on action of $\gamma_F = 1,4$.

²⁾ Not part of the ETA-assessment.

³⁾ Spacing of 77 mm (standard awning console).

⁴⁾ δ_{v0} = Initial deflection / $\delta_{v\infty}$ = long-term deflection

Insulation fixings

how to choose the right product



How to fasten to insulated façades

There are two ways of fastening to the insulated façade, depending on the weight of the attachment part you want to install.

Choose between CELO's insulation fixings for lighter or heavy loads in accordance with the load of the attachment.



Direct fixing of lighter loads

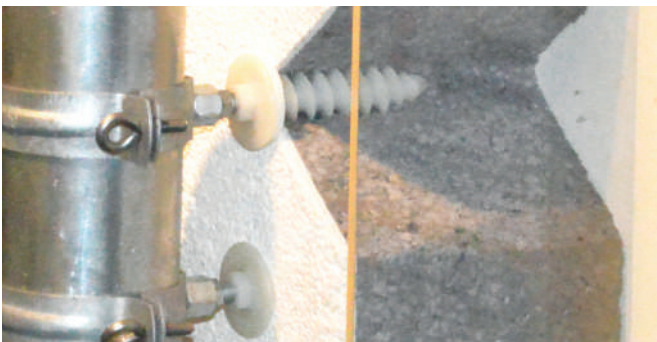

- Can be screwed directly into the insulation
- No pre-drilling thanks to the sharp drilling tip
- Fast and easy solution for fixing rainwater downpipes, lamps and more



Distance mounting for heavy loads



- The fastening product bridges a distance that does not offer enough support for heavy loads (here: the thermal insulation)
- Secure anchoring in the wall while ensuring thermal separation

What is thermal bridging and why you should avoid it?

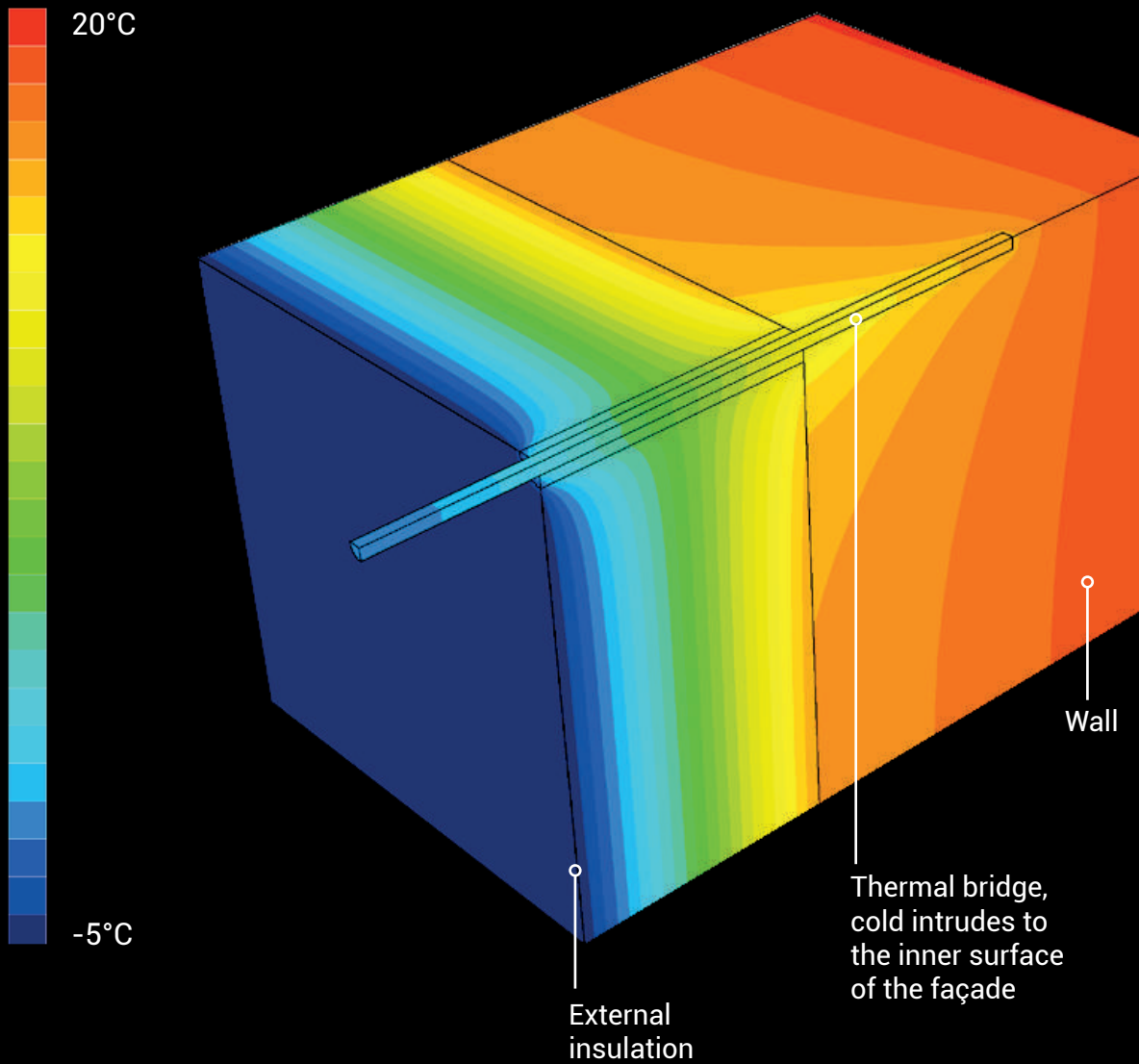

What are thermal bridges?

Thermal bridges, also known as heat bridges or cold bridges, are areas on the building envelope where heat escapes to the outside particularly quickly.

They can arise by subsequent installations on the insulated façade, such as awnings, letterboxes, lamps, etc. The disruption of the insulation can cause increased heat transmission and there is a

risk of heat loss and a thermal bridge at the attachment point with negative consequences like increased heating costs, mould and health risk, reduced living comfort and safety hazards and damages to the building envelope.

This is why it is important to use fixing products that ensure thermal separation.

Why you should avoid thermal bridges?



1. Increased heating costs

In order to compensate for the heat loss and maintain the interior temperature, more heating is required. If moisture enters the façade due to insufficient sealing at the fixing point, the heat loss and energy consumption increases significantly, because water has a 25x higher thermal conductivity than air. If the heat loss accumulates at several points, your electricity and heating bills can increase drastically.



2. Mould and health risk

As a result of the increased heat movement, the cold penetrates to the inner surface of the wall, causing cold spots on the walls and a low surface temperature. Since cold air can bind less water, the relative humidity rises to the point of condensation. Damp and cold walls and an increased risk of mould growth are the results. Microorganisms such as mould and bacteria can then impair room hygiene and personal health.



3. Reduced living comfort and air draught

Cool surfaces at home reduce comfort and well-being and the thermal air movement between warm and cold air layers gives the feeling of a draught. A constant draught and cooler temperatures can lead to colds or sore throats.



4. Safety hazard and damages

If the fixing point on the façade is not optimally sealed, condensation of moisture and the entry of rainwater can also cause damage to the outer façade. Rusting fastening parts can pose a safety risk and the penetration of cold or moisture can lead to structural damage in the long term.

Insulation fixings from CELO

No thermal bridges

As a manufacturer of fixings with 60 years of experience, CELO has developed an innovative range of insulation plugs and screws specially adapted for use on external insulation. They reliably ensure thermal separation, thus preventing the formation of heat bridges in the first place.

Made of high-quality, weather- and UV-resistant nylon, CELO's fixing solutions are not thermally conductive and offer durable corrosion protection through the use of stainless steel and zinc flake coating. In addition, almost all products have an integrated sealing ring so that they optimally seal the façade.

Innovative thread geometries and features like sharp drilling tips speed up the mounting process and help saving mounting time and money.



60 years of experience in fixings



Innovative time saving products



High-quality fixing solutions



Find out more at
www.celofixings.com

Why CELO?

- ✓ Insulation products made of high-quality, weather- and UV-resistant nylon
- ✓ Therefore not thermally conductive
- ✓ Durable corrosion protection through the use of stainless steel and zinc flake coating
- ✓ Integrated sealing ring in most products for optimal sealing of the façade
- ✓ Helps keep thermal separation
- ✓ Energy efficiency and reduction of energy costs

CELO Befestigungssysteme GmbH
Industriestraße 6
D-86551 Aichach
www.celofixings.com
Hotline: +49 (0) 8251-90485-0
Telefax: +49 (0) 8251-90485-49
E-mail: info@celofixings.de

Presented by: